



NOMAD™

OPERATION MANUAL

PWR-FLO™

NPF250 METALLIC PUMP (BOLTED)
PWR-FLO™ AIR DISTRIBUTION SYSTEM



AIR-OPERATED  DOUBLE DIAPHRAGM  PUMPS

ALUMINUM

STAINLESS STEEL Models



A JDA Global Company

CAUTION: Do not apply compressed air to the exhaust port – pump will not function.

CAUTION: Do not over-lubricate air supply – excess lubrication will reduce pump performance. Pump is pre-lubed.

TEMPERATURE LIMITS:
 Neoprene -17.7°C to 93.3°C 0°F to 200°F
 Buna-N -12.2°C to 82.2°C 10°F to 180°F
 EPDM -15.1°C to 137.8°C -60°F to 280°F
 NOTE: Not all materials are available for all models. Refer to Section 2 for material options for your pump.

CAUTION: Check temperature limits for all wetted components. Example: Viton® has a maximum limit of 176.7°C (350°F) but polypropylene has a maximum limit of only 79°C (175°F).

CAUTION: Maximum temperature limit are based upon mechanical stress only. Certain chemicals will significantly reduce maximum safe operating temperatures.

WARNING: Prevention of static parking – if static sparking occurs, fire or explosion could result. Pump, valves, and containers must be grounded to a proper grounding point when handling flammable fluids and whenever discharge of static electricity is a hazard.

CAUTION: Do not exceed 8.6 bar (125psig) air supply pressure.

CAUTION: The process fluid and cleaning fluids must be chemically compatible with all wetted pump components.

CAUTION: Do not exceed 82°C (180°F) air inlet temperature.

CAUTION: Pumps should be thoroughly flushed before installing into process lines.

CAUTION: Always wear safety glasses when operating pump. If diaphragm rupture occurs, material being pumped may be forced out air exhaust.

CAUTION: Before any maintenance or repair is attempted, the compressed air line to the pump should be disconnected and all air pressure allowed to bleed from pump. Disconnect all intake, discharge and air lines. Drain the pump by turning it upside down and allowing any fluid to flow into a suitable container.

CAUTION: Blow out air line for 10 to 20 seconds before attaching to pump to make sure all pipeline debris is clear. Use an in-line air filter. A 5µ (micron) air filter is recommended.

NOTE: When installing PTFE diaphragms, it is important to tighten outer pistons simultaneously (turning in opposite directions) to ensure a tight fit. (See torque specifications.)

NOTE: Before starting disassembly, mark a line from each liquid chamber to its corresponding air chamber. This line will assist in proper alignment during reassembly.

CAUTION: Tighten all hardware prior to installation.



Pump Designation System



XXX XX / XXXX / XX / XX / XXX / X/X/X

1	2	3	4	5	6	7	8	9	10	11	12	13				
Air Distribution System	Liquid Port Size	Wetted Parts	Air Chambers			Diaphragms	Valve Balls	Valve Seats	Fittings			Connections	ATEX			
N	07	A	BN	BN	BN	Buna	BN	Buna	A	Aluminum	N	NPT	C	Clamped	X	ATEX
T	15	W	BN	BN	BN	Buna Maxi-Flex	FG	Hytrel®	BN	Buna	B	BSP	B	Bolted		
TG	25	S	FG	FG	FG	Hytrel®	ND	Nordel®/EPDM	FG	Hytrel®	TC	Tri-Clamp				
PF	250	P	FGF	FGF	FGF	Hytrel® UFI	NE	Neoprene	K	Kynar®/PVDF	FLA	Flanged ANSI				
	40	4	GLF	GLF	GLF	Geolast UFI	PE	Polyethylene	M	Mild Steel	FLD	Flanged DIN				
	50	A	ND	ND	ND	Nordel®/EPDM	PU	Polyurethane	ND	Nordel®/EPDM						
	80	W	NDU	NDU	NDU	Nordel®/EPDM Maxi-Flex	SF	Santoprene® Food Grade	NE	Neoprene						
	100	S	NE	NE	NE	Neoprene	SN	Santoprene®	P	Polypropylene						
		W	NEU	NEU	NEU	Neoprene Maxi-Flex	S	Stainless Steel	PE	Polyethylene						
		P	PU	PU	PU	Polyurethane	TF	PTFE	PU	Polyurethane						
		5	PUF	PUF	PUF	Polyurethane UFI	VT	Viton®	S	Stainless Steel						
		A	SGF	SGF	SGF	Santoprene® Food Grade-UFI			SF	Santoprene® Food Grade						
		S	SN	SN	SN	Santoprene®			SN	Santoprene®						
		P	SNF	SNF	SNF	Santoprene®-UFI			VT	Viton®						
		6	SNG	SNG	SNG	Santoprene® Food Grade			10	O-Ring						
		B	TF	TF	TF	PTFE Neoprene back-up			BN	Buna						
		P	TFF	TFF	TFF	PTFE - UFI Santoprene® back up			ND	Nordel®/EPDM						
		A	TFG	TFG	TFG	PTFE - UFI Hytrel® back up			NE	Neoprene						
		S	TFH	TFH	TFH	PTFE - Hytrel® back up			PTV	Viton Encap.						
			TGE	TGE	TGE	Garlock® - EPDM BACKED			PU	Polyurethane						
			TGN	TGN	TGN	Garlock® - NEO BACKED			SF	Santoprene® Food Grade						
			TGV	TGV	TGV	Garlock® - Viton BACKED			SN	Santoprene						
			TND	TND	TND	PTFE Nordel back up			TF	PTFE						
			VT	VT	VT	Viton®/FKM			VT	Viton®						
			VTU	VTU	VTU	Viton®/FKM Maxi-Flex										

NTG 50 / AAAB / TF / TF / ATF / N/C/X

1	2	3	4	5	6	7	8	9	10	11	12	13				
Air Distribution System	Liquid Port Size	Wetted Parts	Air Chambers			Diaphragms	Valve Balls	Valve Seats	Fittings			Connections	ATEX			
N	50	A	TF	TF	TF	PTFE (with Neo back-up)	TF	PTFE	A	Aluminum	N	NPT	C	Clamped	X	ATEX
T		4	A	A	A	Aluminum			10	O-Ring						
TG		5	A	A	A	Aluminum			TF	PTFE						
PF		6	B	B	B	Brass										

The NOMAD diaphragm pump is an air-operated, positive displacement, self-priming pump. These drawings show flow pattern through the pump upon its initial stroke. It is assumed the pump has no fluid in it prior to its initial stroke.

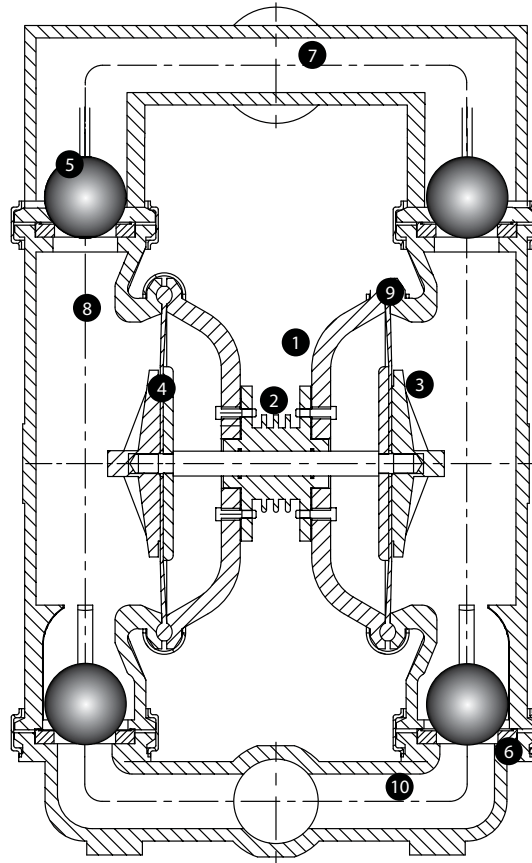

1. Air Chamber

The air chamber is the chamber that houses the air which powers the diaphragms.

2. Air Distribution System

The air distribution system is the heart of the pump. The air distribution system is the mechanism that shifts the pump in order to create suction and discharge strokes.

3. Lock Nut (Outer Diaphragm Piston)

The outer diaphragm pistons provide a means to connect the diaphragms to the reciprocating common shaft and to seal the liquid side from the air side of the diaphragm.

4. Holding plate (Inner Diaphragm Piston)

The inner piston is located on the air side of the pump and does not come into contact with the process fluid.

5. Check Valve Ball

NOMAD air-operated pumps use suction and discharge check valves to produce directional flow of process fluid in the liquid chamber. The check valve balls seal and release on the check valve seats allowing for discharge and suction of process fluid to occur.

6. Check Valve Seat

The removable seats provide the ball valves a site to check.

7. Discharge Manifold

Process fluid exits the pump from the discharge port located on the discharge manifold at the top of the pump.

8. Liquid Chamber

The liquid chamber is filled with the process fluid during the suction stroke and is emptied during the discharge stroke. It is separated from the compressed air by the diaphragms.

9. Diaphragm

The diaphragm membrane provides for separation of the process fluid and the compressed air power source. To perform adequately, diaphragms should be of sufficient thickness and of appropriate material to prevent degradation or permeation in specific process fluid applications. TABLA offers a variety of diaphragm materials for your specific application requirements.

10. Inlet Manifold

Process fluid enters the pump from the intake port located on the inlet manifold at the bottom of the pump.

Troubleshooting

Pump will not run or runs slowly.

1. Ensure that the air inlet pressure is at least 0.4 Bar (5 psig) above start up pressure and that the differential pressure (the difference between air inlet and liquid discharge pressures) is not less than 0.7 Bar (10 psig).
2. Check air inlet filter for debris
3. Check for extreme air leakage (blow by) which would indicate worn seals/bores in the air valve.
4. Disassemble pump and check for obstructions in the air passageway.
5. Check for sticking ball check valves. If material being pumped is not compatible with pump, elastomer, swelling may occur. Replace ball check valves and seals with proper elastomers. Also, as the check valve balls wear out, they become smaller and can become stuck in the seats. In this case, replace balls and seats.
6. Check for broken inner piston which will cause the air valve spool to be unable to shift.
7. Remove plug from pilot spool exhaust.

Pump runs but little or no product flows.

1. Check for pump cavitation; slow pump speed down to allow thick material to flow into liquid chambers.
2. Verify that vacuum required to lift is not greater than the vapor pressure of the material being pumped (cavitation).
3. Check for sticking ball valves. If material being pumped is not compatible with pump elastomers, swelling may occur. Replace ball check valves and seats with proper elastomers. Also, as the check valve balls wear out, they become smaller and can become stuck in the seats. In this case, replace balls and seats.

Pump air valve freezes.

1. Check for excessive moisture in compressed air. Either install a dryer or hot air generator for compressed air. Alternatively, a coalescing filter may be used to remove the water from the compressed air in some applications.

Air bubbles in pump discharge.

1. Check for ruptured diaphragm.
2. Check tightness of outer pistons.
3. Check tightness of fasteners and integrity of o-rings and seals, especially at intake manifold.
4. Ensure pipe connections are airtight

Product comes out air exhaust.

1. Check for diaphragm rupture.
2. Check tightness of outer pistons to shaft.

INSTALLATION:

- Suction pipe equal to/greater than pump diameter (same for discharge)
- Tighten all fasteners before use
- Suction connection should be non-collapsible

AIR SUPPLY:

- Air line size must be large enough to create desired volume (see performance curve section)
- Do not exceed 8.6 BAR (125 PSIG)
- For best results, use 5 micron air filter
- Use lubricator with 5 wt. oil

PIPING:

- Remove as many turns/elbows as possible
- Piping should be supported
- Flexible hose will avoid stress on pump fitting
- Gate Valve should be used in applications involving flooded suction
- In positive suction head conditions, limit inlet pressure to 0.5 - 0.7 BAR (7 - 10 PSI). Premature diaphragm failure will take place above the parameters.

ALL NOMAD PUMPS ARE CAPABLE OF PASSING SOLIDS. A STRAINER SHOULD BE USED ON THE PUMP INTAKE TO ENSURE THAT THE PUMP'S RATED SOLIDS CAPACITY IS NOT EXCEEDED.

CAUTION: DO NOT EXCEED 8.6 BAR (125 PSIG) AIR SUPPLY PRESSURE.

Suggested Installation

This illustration is a generic representation of an air-operated double-diaphragm pump.

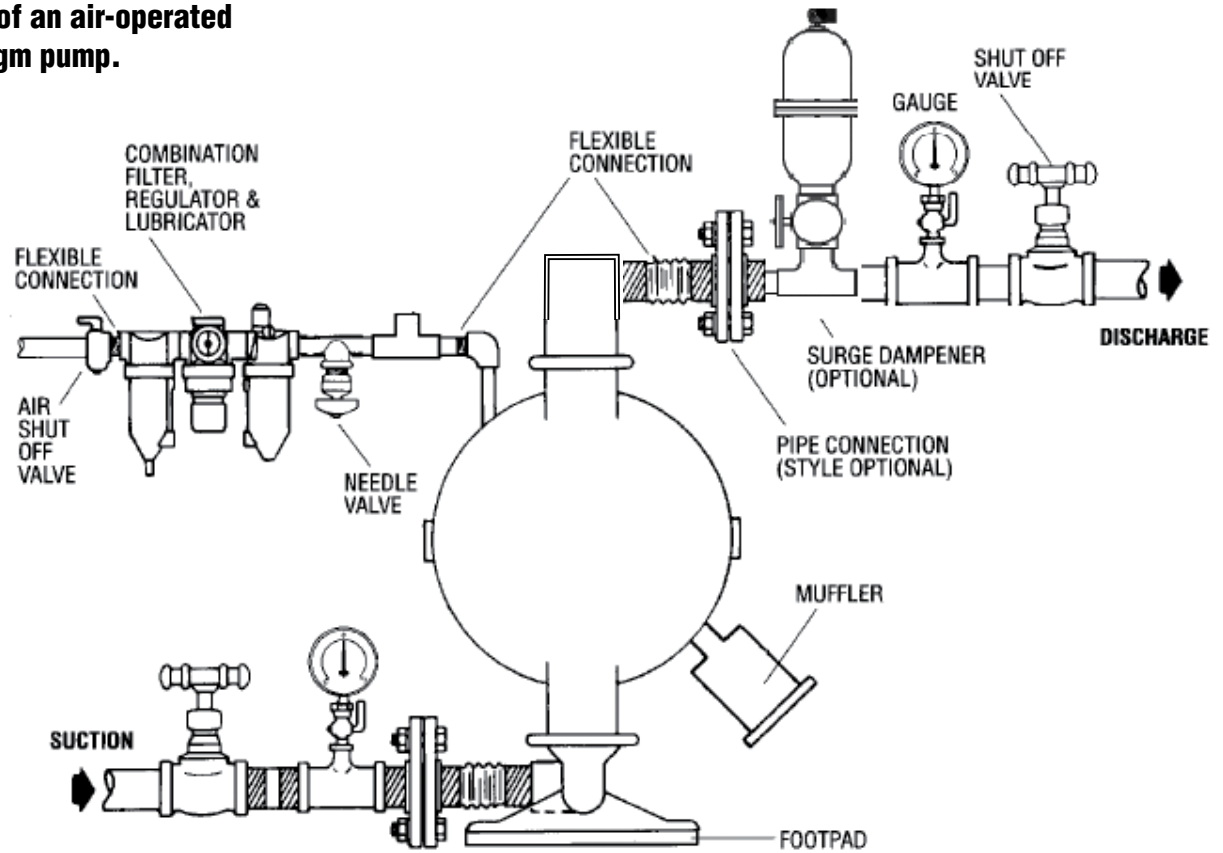

NOTE: In the event of a power failure, the shut off valve should be closed, if the restarting of the pump is not desirable once power is regained.

AIR OPERATED PUMPS: To stop the pump from operating in an emergency situation, simply shut off valve (user supplied) installed

in the air supply line. A properly functioning valve will stop the air supply to the pump, therefore stopping output. The shut off valve should be located far enough away from the pumping equipment such that it can be reached safely in an emergency situation.

NPF 250 METAL THREADED

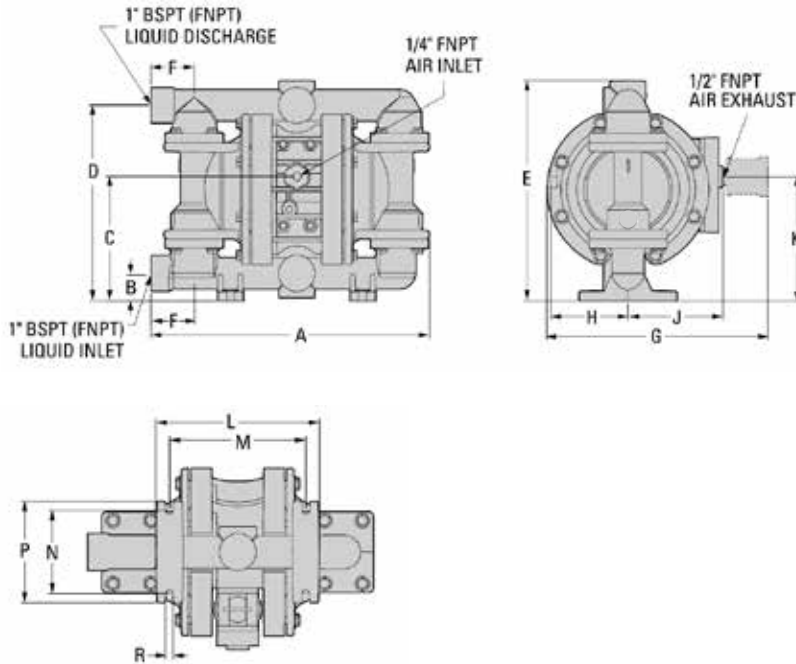

ITEM	METRIC (mm)	STANDARD (inch)
A	361	14.2
B	36	1.4
C	163	6.4
D	254	10.0
E	287	11.3
F	56	2.2
G	287	11.3
H	99	3.9
J	122	4.8
K	160	6.3
L	206	8.1
M	173	6.8
N	104	4.1
P	127	5.0
R	10	0.4

NPF 250 STAINLESS STEEL/ALUMINUM FLANGE

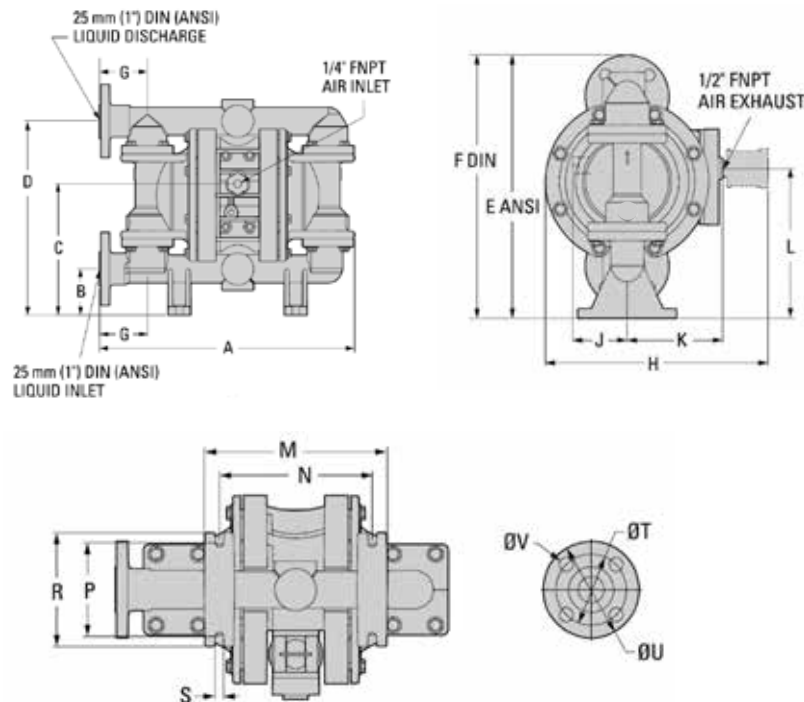

ITEM	METRIC (mm)	STANDARD (inch)
A	373	14.7
B	69	2.7
C	195	7.6
D	287	11.3
E	340	13.4
F	343	13.5
G	71	2.8
H	287	11.3
J	71	2.8
K	122	4.8
L	193	7.6
M	206	8.1
N	173	6.8
P	104	4.1
R	127	5.0
S	10	0.4
A	373	14.7

DIN FLANGE		
T	85 DIA.	3.3 DIA.
U	115 DIA.	4.5 DIA.
V	14 DIA.	0.6 DIA.

ANSI FLANGE		
T	79 DIA.	3.1 DIA.
U	109 DIA.	4.3 DIA.
V	14 DIA.	0.6 DIA.

LW0445 REV. A

NPF250 METAL RUBBER FITTED

Ship Weights.....Aluminum 11 kg (24 lb)
 316 Stainless Steel 23 kg (51 lb)
 Air Inlet.....1/4"
 Inlet......25 mm (1")
 Outlet......25 mm (1")
 Suction Lift.....5.4 m Dry (17.6')
 9.3 m Wet (30.6')
 Disp. per Stroke¹.....0.30L (0.08 gal)
 Max. Flow Rate.....212 lpm (56 gpm)
 Max. Size Solids.....6.4 mm (1/4")

¹Displacement per stroke was calculated at 4.8 bar (70 psig) air inlet pressure against a 2.1 bar (30 psig) head pressure.

Example: To pump 56.8 lpm (15 gpm) against a discharge head of 3.3 bar (48 psig) requires 4.1 bar (60 psig) and 34 Nm³/h (20 scfm) air consumption.

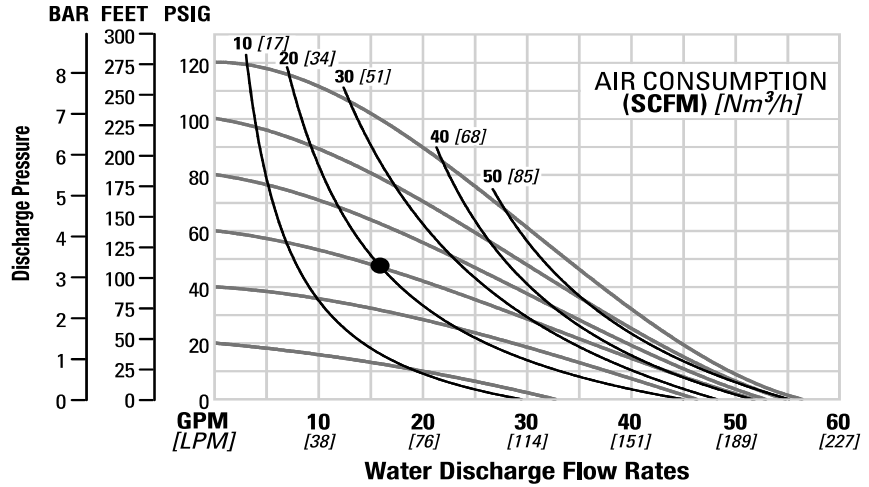

Flow rates indicated on chart were determined by pumping water. For optimum life and performance, pumps should be specified so that daily operation parameters will fall in the center of the pump's performance curve.

Caution: Do not exceed 8.6 bar (125 psig) air supply pressure.

NPF250 METAL TPE-FITTED

Ship Weights.....Aluminum 11 kg (24 lb)
 316 Stainless Steel 23 kg (51 lb)
 Air Inlet.....1/4"
 Inlet......25 mm (1")
 Outlet......25 mm (1")
 Suction Lift.....4.1 m Dry (13.6')
 9.3 m Wet (30.6')
 Disp. per Stroke¹.....0.34L (0.09 gal)
 Max. Flow Rate.....212 lpm (56 gpm)
 Max. Size Solids.....6.4 mm (1/4")

¹Displacement per stroke was calculated at 4.8 bar (70 psig) air inlet pressure against a 2.1 bar (30 psig) head pressure.

Example: To pump 273 lpm (72 gpm) against a discharge head of 2.8 bar (40 psig) requires 5.5 bar (80 psig) and 83 Nm³/h (49 scfm) air consumption.

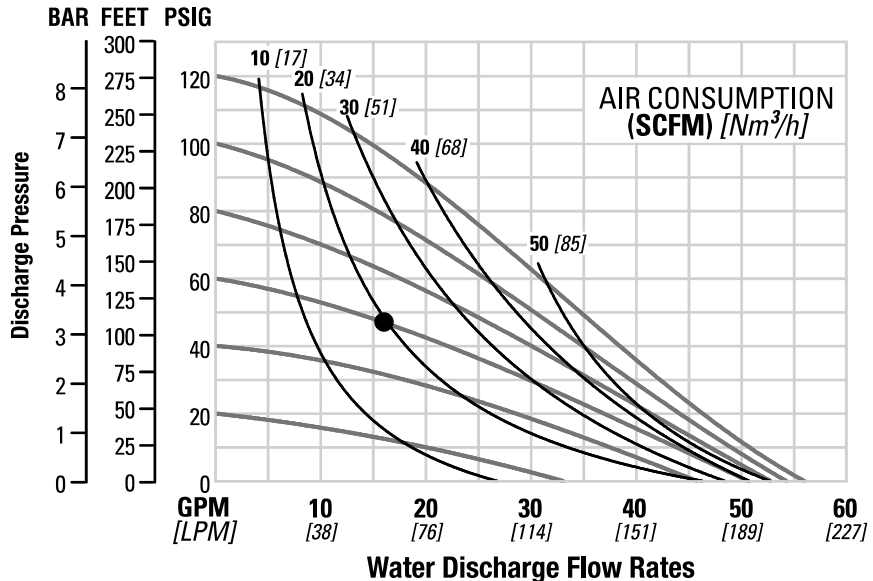

Flow rates indicated on chart were determined by pumping water. For optimum life and performance, pumps should be specified so that daily operation parameters will fall in the center of the pump's performance curve.

Caution: Do not exceed 8.6 bar (125 psig) air supply pressure.

NPF250 METAL PTFE-FITTED

Ship Weights.....Aluminum 11 kg (24 lb)
316 Stainless Steel 23 kg (51 lb)

Air Inlet.....1/4"
Inlet.....25 mm (1")
Outlet.....25 mm (1")
Suction Lift.....3.5 m Dry (11.4')
9.3 m Wet (30.6')
Disp. per Stroke¹.....0.23L (0.06 gal)
Max. Flow Rate.....168 lpm (44 gpm)
Max. Size Solids.....6.4 mm (1/4")

¹Displacement per stroke was calculated at 4.8 bar (70 psig) air inlet pressure against a 2.1 bar (30 psig) head pressure.

Example: To pump 280 lpm (74 gpm) against a discharge head of 2.1 bar (30 psig) requires 5.5 bar (80 psig) and 88 Nm³/h (52 scfm) air consumption.

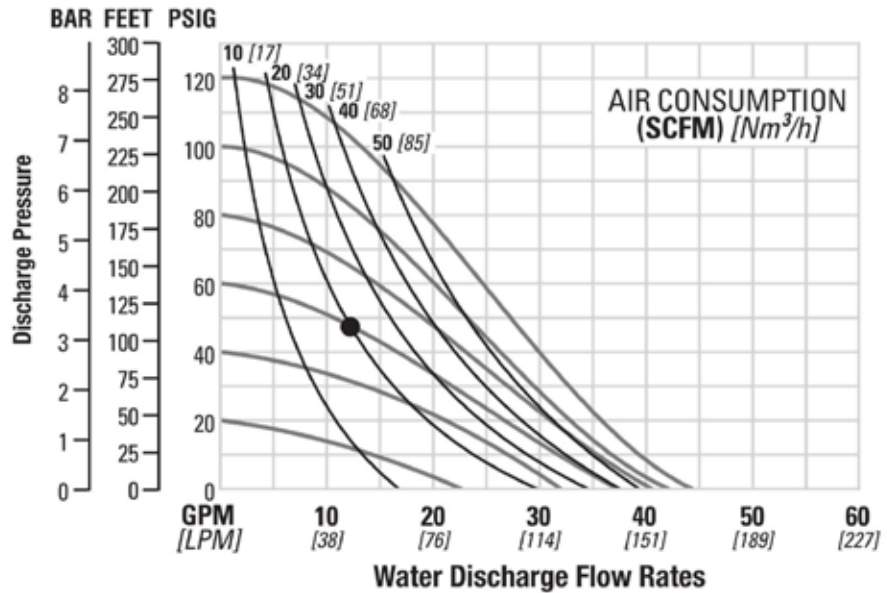

Flow rates indicated on chart were determined by pumping water. For optimum life and performance, pumps should be specified so that daily operation parameters will fall in the center of the pump's performance curve.

Caution: Do not exceed 8.6 bar (125 psig) air supply pressure.

NPF250 METAL UFI PTFE-FITTED

Ship Weights.....Stainless Steel 23 kg (51 lb)
Aluminum 11 kg (24 lb)

Air Inlet.....1/4"
Inlet.....25 mm (1")
Outlet.....25 mm (1")
Suction Lift.....5.5 m Dry (18.2')
9.0 m Wet (29.5')
Disp. per Stroke¹.....0.3L (0.08 gal)
Max. Flow Rate.....185 lpm (49 gpm)
Max. Size Solids.....6.4 mm (1/4")

¹Displacement per stroke was calculated at 4.8 bar (70 psig) air inlet pressure against a 2.1 bar (30 psig) head pressure.

Example: To pump 75.7 lpm (20 gpm) against a discharge head of 3.1 bar (45 psig) requires 4.1 bar (60 psig) and 36.9 Nm³/h (23 scfm) air consumption.

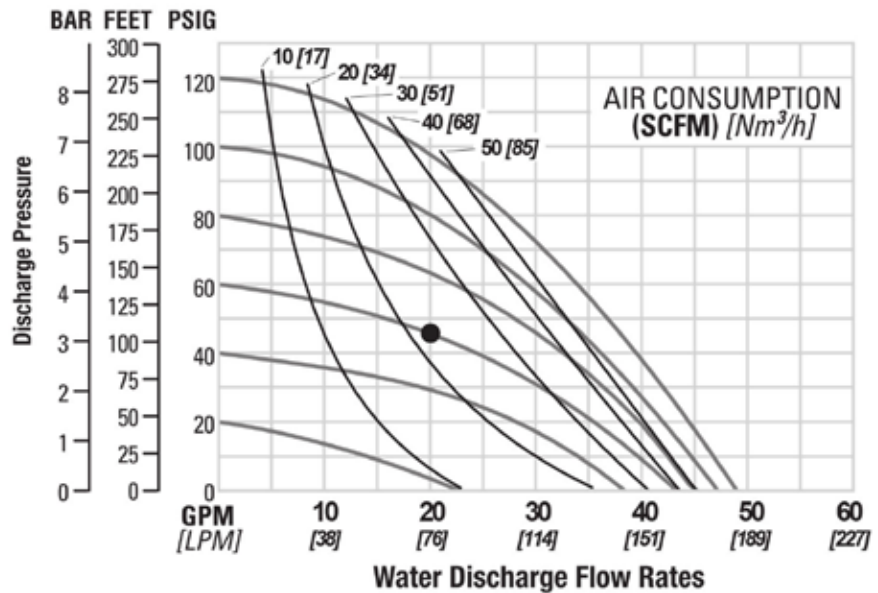

Flow rates indicated on chart were determined by pumping water. For optimum life and performance, pumps should be specified so that daily operation parameters will fall in the center of the pump's performance curve.

Caution: Do not exceed 8.6 bar (125 psig) air supply pressure.

Exploded View & Parts Listing

N O M A D™

NPF 250 RUBBER-FITTED

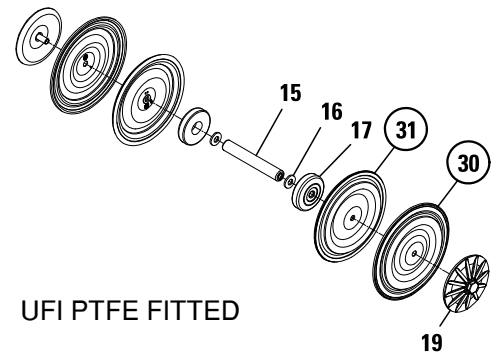
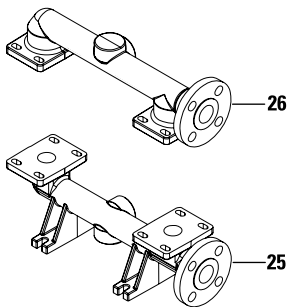
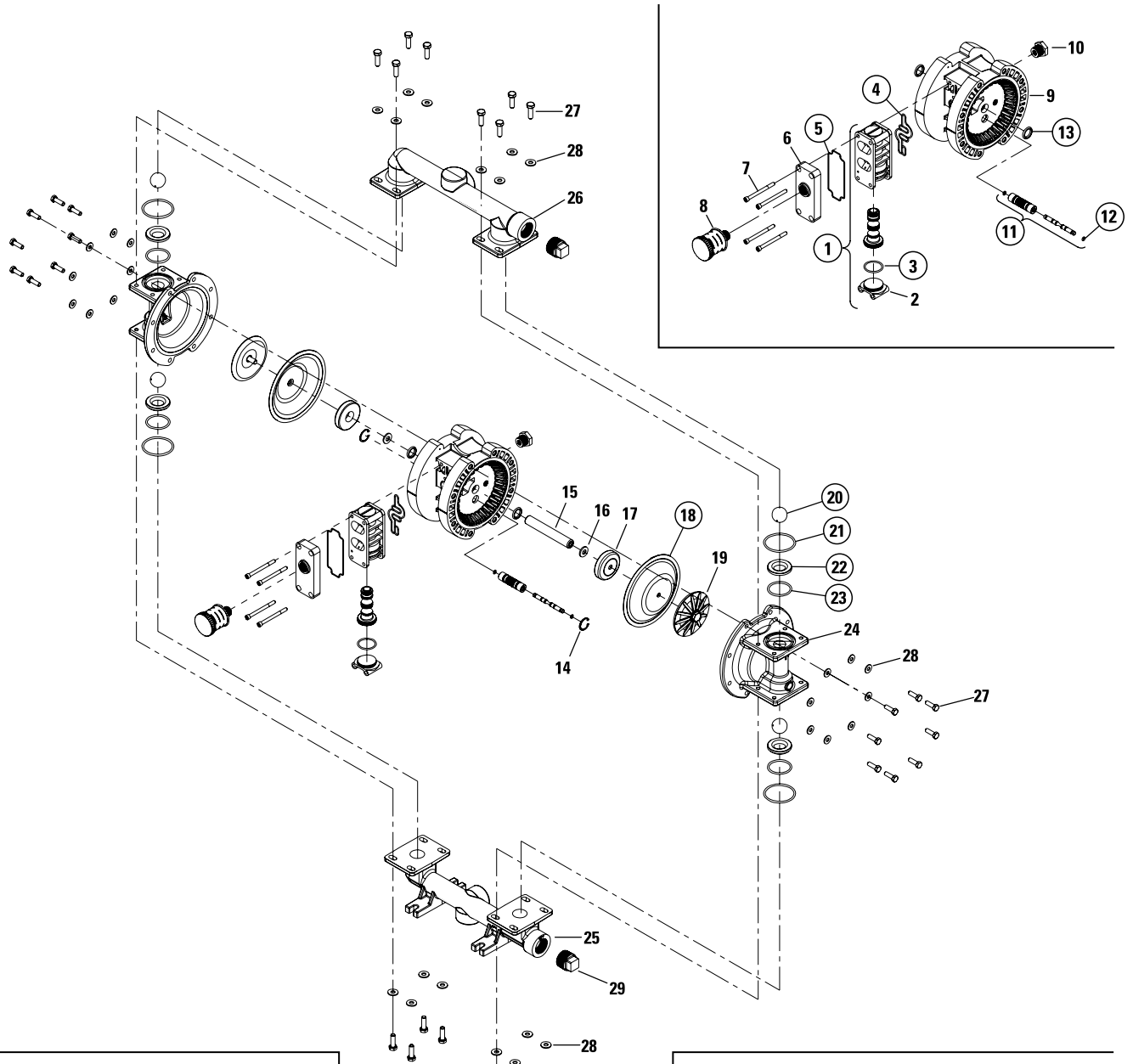

UFI PTFE FITTED

NPF 250 RUBBER-FITTED

No.	Part Description	Qty.	Aluminum	Stainless Steel
1	PWR-FLO® Air Valve	1	N01-2010-20	N01-2010-20
2	End Cap	1	N01-2332-20	N01-2332-20
3	End Cap O-Ring	1	N01-2395-52	N01-2395-52
4	Air Valve Gasket	1	N01-2615-52	N01-2615-52
5	Gasket, Muffler Plate	1	N0-3505-52	N0-3505-52
6	Muffler Plate	1	N01-3181-20	N01-3181-20
7	Screw, SHC (1/4" - 20 x 3")	4	N01-6001-03	N01-6001-03
8	Muffler	1	N02-3880-99	N02-3880-99
9	Center Section	1	N02-3142-20	N02-3142-20
10	Bushing, Reducer	1	N01-6950-20	N01-6950-20
11	Pilot Sleeve Assembly	1	N02-3880-99	N02-3880-99
12	Pilot Spool Retaining O-Ring	2	N04-2650-49-700	N04-2650-49-700
13	Shaft Seal	2	N08-3210-55-225	N08-3210-55-225
14	Retaining O Ring	2	N00-2650-03	N00-2650-03
15	Shaft	1	N02-3810-03	N02-3810-03
16	Diac Spring	2	N02-6802-08	N02-6802-08
17	Inner Piston	2	N02-3701-01	N02-3701-01
18	Diaphragm	2	N02-1010-51	N02-1010-51
19	Outer Piston	2	N02-4550-01	N02-4550-03
20	Ball, Valve	4	N02-1085-51	N02-1085-51
21	Manifold O Ring	4	N02-1372-50	N02-1372-50
22	Seat, Valve	4	N02-1125-01	N02-1125-03
23	Valve Seat, O-Ring	4	N02-1205-51	N02-1205-51
24	Liquid Chamber	2	N02-5015-01	N02-5015-03
25	Inlet Manifold, ANSI Flanged	1	N02-5090-01	N02-5090-03
	Inlet Manifold, DIN Flanged	1	N02-5091-01	N02-5091-03
	Inlet Manifold, Side Ported 1" NPT	1	N02-5095-01	N02-5095-03
	Inlet Manifold, Side Ported 1" BSP	1	N02-5096-01	N02-5096-03
26	Discharge Manifold, ANSI Flanged	1	N02-5030-01	N02-5030-03
	Discharge Manifold, DIN Flanged	1	N02-5031-01	N02-5031-03
	Discharge Manifold, Side Ported 1" NPT	1	N02-5035-01	N02-5035-03
	Discharge Manifold, Side Ported 1" BSP	1	N02-5036-01	N02-5036-03
27	Screw, HHC, 5/16-18 x 1"	32	N08-6180-03-42	N08-6180-03-42
28	Washer, 5/16	32	N02-6731-03	N02-6731-03
29	Pipe Plug 1" NPT	2	N02-7010-01	N02-7010-03
	Pipe Plug 1" BSP	2	N02-7011-01	N02-7011-03

Exploded View & Parts Listing

N O M A D™

NPF 250 PTFE FITTED

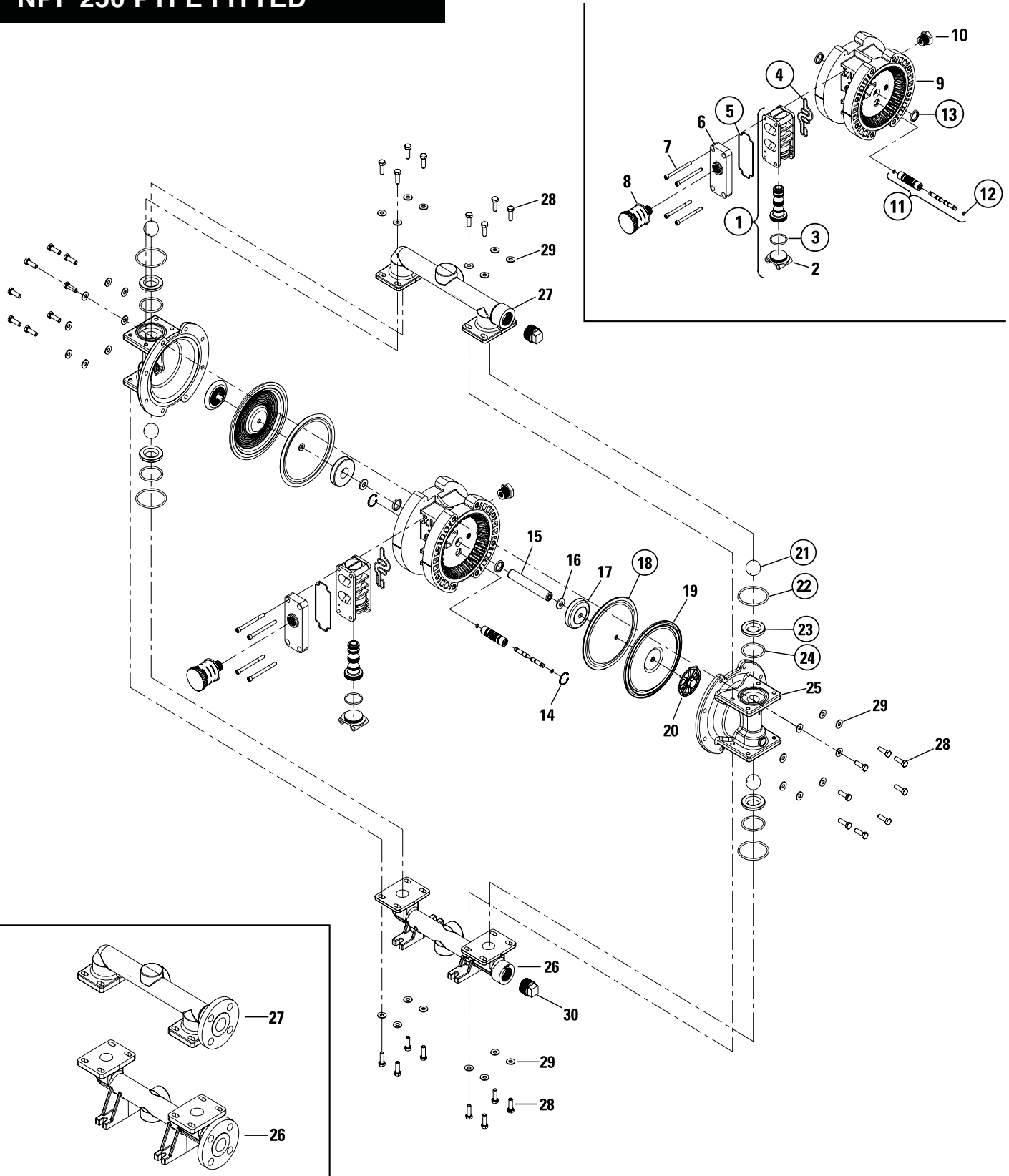

NPF 250 PTFE FITTED

No.	Part Description	Qty.	Aluminum	Stainless Steel
1	PWR-FLO® Air Valve	1	N01-2010-20	N01-2010-20
2	End Cap	1	N01-2332-20	N01-2332-20
3	End Cap O-Ring	1	N01-2395-52	N01-2395-52
4	Air Valve Gasket	1	N01-2615-52	N01-2615-52
5	Gasket, Muffler Plate	1	N0-3505-52	N0-3505-52
6	Muffler Plate	1	N01-3181-20	N01-3181-20
7	Screw, SHC (1/4" - 20 x 3")	4	N01-6001-03	N01-6001-03
8	Muffler	1	N02-3880-99	N02-3880-99
9	Center Section	1	N02-3142-20	N02-3142-20
10	Bushing, Reducer	1	N01-6950-20	N01-6950-20
11	Pilot Sleeve Assembly	1	N02-3880-99	N02-3880-99
12	Pilot Spool Retaining O-Ring	2	N04-2650-49-700	N04-2650-49-700
13	Shaft Seal	2	N08-3210-55-225	N08-3210-55-225
14	Retaining O Ring	2	N00-2650-03	N00-2650-03
15	Shaft	1	N02-3840-03	N02-3840-03
16	Diac Spring	2	N02-6802-08	N02-6802-08
17	Inner Piston	2	N02-3751-01	N02-3751-01
18	Back Up Diaphragm	2	N02-1060-51	N02-1060-51
19	Diaphragm	2	N02-1010-55	N02-1010-55
20	Outer Piston	2	N02-4601-01	N02-4600-03
21	Ball, Valve	4	N02-1085-55	N02-1085-55
22	Manifold O Ring	4	N70-1280-55	N70-1280-55
23	Seat, Valve	4	N02-1125-01	N02-1125-03
24	Valve Seat, O-Ring	4	N02-1205-55	N02-1205-55
25	Liquid Chamber	2	N02-5015-01	N02-5015-03
26	Inlet Manifold, ANSI Flanged	1	N02-5090-01	N02-5090-03
	Inlet Manifold, DIN Flanged	1	N02-5091-01	N02-5091-03
	Inlet Manifold, Side Ported 1" NPT	1	N02-5095-01	N02-5095-03
	Inlet Manifold, Side Ported 1" BSP	1	N02-5096-01	N02-5096-03
27	Discharge Manifold, ANSI Flanged	1	N02-5030-01	N02-5030-03
	Discharge Manifold, DIN Flanged	1	N02-5031-01	N02-5031-03
	Discharge Manifold, Side Ported 1" NPT	1	N02-5035-01	N02-5035-03
	Discharge Manifold, Side Ported 1" BSP	1	N02-5036-01	N02-5036-03
28	Screw, HHC, 5/16-18 x 1"	32	N08-6180-03-42	N08-6180-03-42
29	Washer, 5/16	32	N02-6731-03	N02-6731-03
30	Pipe Plug 1" NPT	2	N02-7010-01	N02-7010-03
	Pipe Plug 1" BSP	2	N02-7011-01	N02-7011-03

Exploded View & Parts Listing



NPF250 GuardEX™

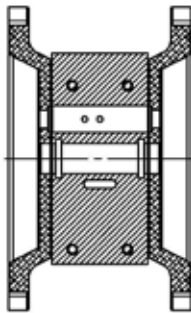
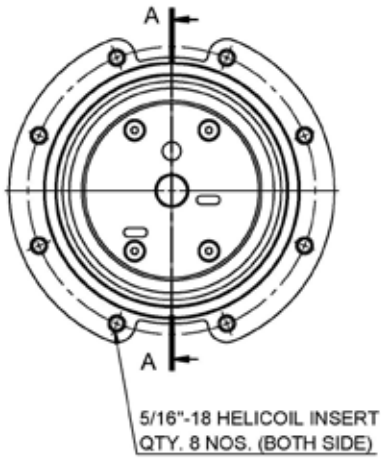

SECTION A-A

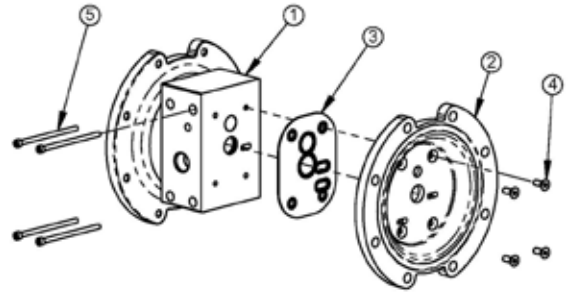

No.	Part Description	Qty.	Part Number	MOC
1	Centre Block	1	N02-3110-01	Aluminium
2	Air Chamber with Helicoil Insert	2	N02-3681-01	Aluminium
3	Center Block Gasket	2	N02-3500-52-700	BUNA-N
4	Air Chamber Bolts M6-1.0x16L	8	N02-6250-03	SS304
5	Air Valve Screws M5-0.8x90L	4	N02-6003-03-700	SS304



A JDA Global Company

150 Cassia Way, SUITE 400
Henderson, Nevada 89014
(702) 331-3740

N O M A D™



NO BOUNDARIES™